



World Wide - World Class

Gaylord Conveyors



Horizontal conveyors used to convey shredded material away from size reduction equipment

RI-16/10

Standard Specifications

- Sliderbed conveyor constructed of reinforced steel trough with straight sidewalls
- Dimension: 10' long bed length, 16" wide, 4.5' discharge height, 6" sidewalls
- Rubber sidewall skirting retains material on belt
- Adjustable support legs with mounting pads
- Bolt-on infeed hopper
- PVC belting with metal cleats at 24" centers
- Standard belt speed: 94 fpm
- Heavy duty crowned head and winged tail pulleys
- Tail pulley cover
- 1 HP TEFC motor, 230/460V, 3 PH, 60 HZ. Others available
- Maximum load / full load capacity: 1,500 lbs

Available Options: Magnetic head pulleys

This standard conveyor is part of our "Quick Ship" Program

Gaylord Conveyors

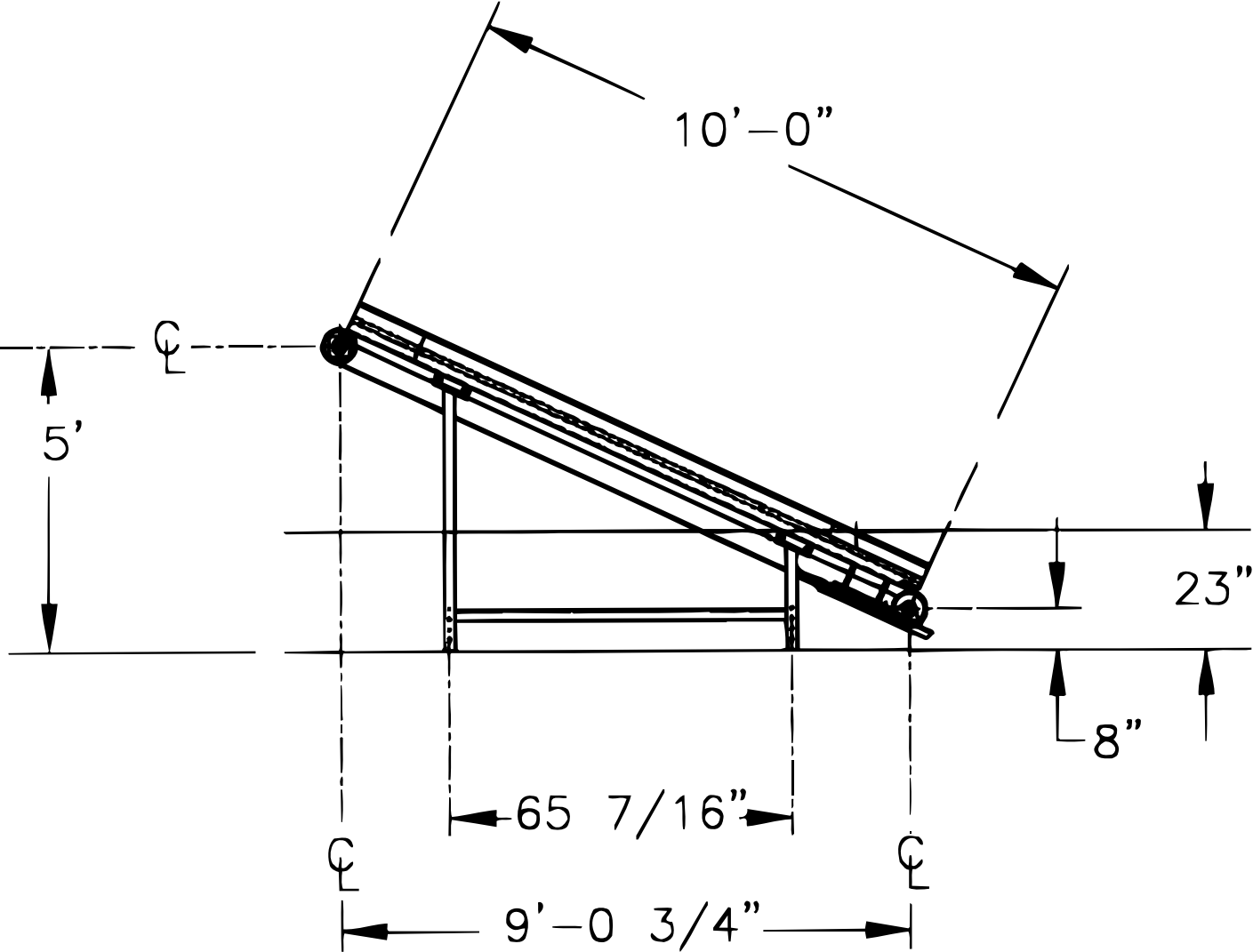

Vecoplan, LLC

P.O. Box 7224 • High Point, NC 27264
Phone: (336) 861-6070 • Fax: (336) 861-4479
www.VecoplanLLC.com